

Bridging Circuits and Electromagnetics in a Curriculum aimed at Microelectronic Analog and Microwave Simulation and Design

Vikram Jandhyala, Yasuo Kuga, David Allstot, and C.J. Richard Shi

*Department of Electrical Engineering
Box 352500, University of Washington
Seattle WA 98195
jandhyala@ee.washington.edu*

Abstract

Higher operating frequencies and increased integration have led to electromagnetic effects being ubiquitous in microelectronics for digital, analog, and RF applications at the board, package, and chip levels. Classical curricula have tended to teach circuits and electromagnetics as two distinct areas. This paper presents courses at the University of Washington that aim to bridge the circuit-electromagnetic gap by teaching electromagnetics top-down “on demand” i.e. at the level of complexity required for a given application rather than the bottom-up approach of classical electromagnetics that did not necessarily mesh well with circuits curricula.

1. Introduction

The circuit-electromagnetic curriculum at UW consists of several senior and graduate courses. Those courses with an electromagnetics flavor include EE467 (Antennas), EE 480 (Microwave engineering), EE 481 (Microwave design), EE 571 (Electromagnetics for High-speed circuits), and EE 573 (Computational electromagnetics). All courses are project-based, application-oriented, and use electromagnetics in a top-down, demand-driven manner suitable to the specific microelectronic application under study or design. Two courses are discussed here, EE 481 and EE 571. In EE 481, senior students are introduced to microwave design. Students use modern electromagnetic simulation and design CAD tools and fabricate system components using transmission line methods on printed circuit boards. In EE 571, circuit-oriented electromagnetic methods are developed in course projects including multiconductor transmission line models, transient and steady-state simulation, parameter extraction techniques, and reduced-order models. In the proposed presentation, the complete curriculum will be discussed and summarized.

2. Curriculum Sample: Microwave Design in EE 481

EE481 is an EM capstone design course and is organized to teach analysis, simulations, fabrications, and testing of microwave circuits. After an introduction on the use of Ansoft Designer CAD software and testing equipment, EE481 students work on the following sample projects. Student names are embedded in the figures.

(1) 180 degree hybrid at 2 GHz

Students are asked to design a hybrid within a limited area. Unlike a traditional hybrid, this requires the addition of bends and extensive numerical simulations to adjust phase. Some examples are shown here.

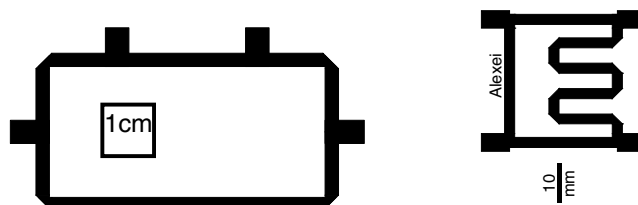

(2) 4GHz low pass filter

The LPF design based on an ideal TL has serious problem beyond 2 GHz and the EM simulations must be conducted to get a correct cutoff frequency. The purpose of this project is to show the importance of the EM based simulations.

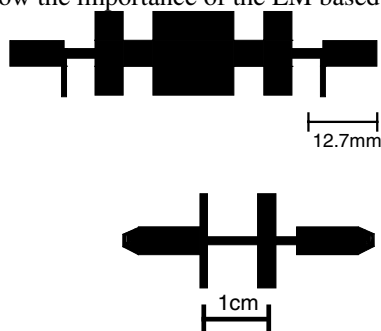

(3) Final project: 2GHz narrowband amplifier
 The final project involves all subjects learned in EE481. One example is the narrowband amplifier centered at 2 GHz and the bandwidth of less than 100 MHz. Utilizing all knowledge and design tools learnt in the previous projects, most EE481 students are able to come up with his/her own designs. One example is shown below, with the layout, circuit schematic, and scattering matrix results.

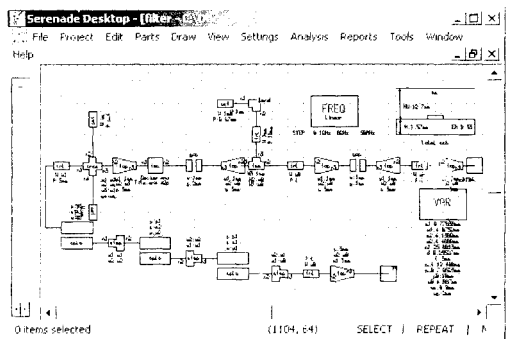
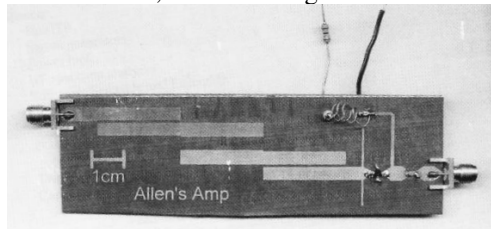

Circuit used to create the amplifier layout. The band pass filter is bent over to save space.

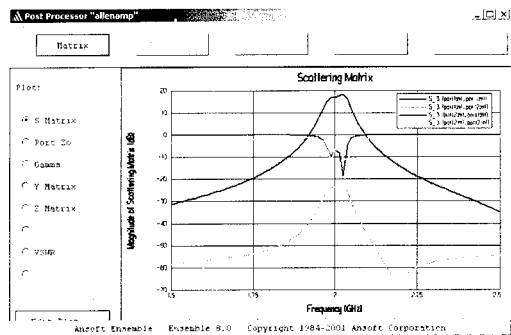

Ensemble simulation showing the pass band at 2GHz.

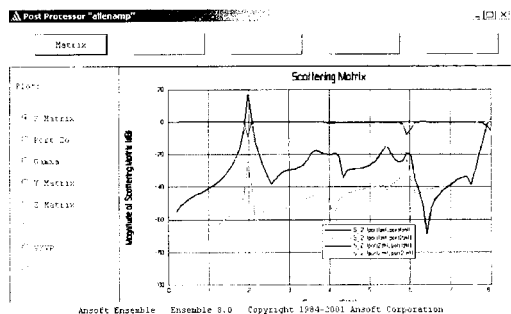

Ensemble simulation showing the attenuation of the harmonics by the notch filters.

3. Curriculum Sample: High-Speed Circuit Effects Modeling in EE 571

Students are first taught multi-conductor transmission line equations. The first computing project in Matlab involves creating an RLGC matrix simulator for transmission lines. Layered media methods are taught and developed for multi-layered boards and substrates. Reduced-order model techniques, particularly asymptotic waveform evaluation, are discussed. Finally, a programming course project involving a complete multi-conductor transmission line simulator, including parasitic extraction in layered media, model order reduction, and transient simulation is developed. Shown below are results of model order reduction on transmission lines (top), and transient simulation (bottom) through a co-planar waveguide with and without a decoupling capacitor, and with and without a split ground plane. The overall course structure enables students to understand what technique to use in which aspect of high-speed circuit modeling.

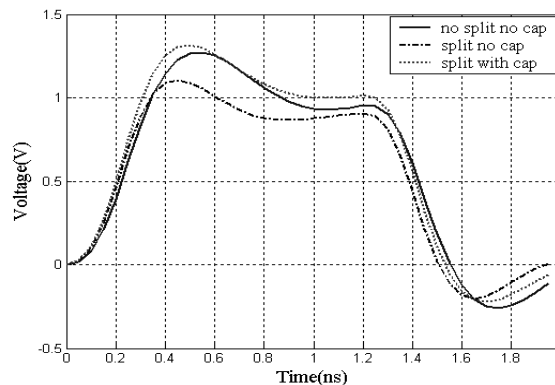
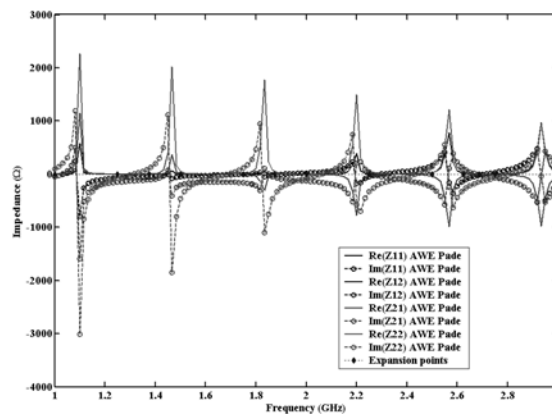

ACKNOWLEDGMENTS

We would like to acknowledge support from the NSF Combined Research and Curriculum Development program, software donations from Ansoft corporation, and discussions and suggestions from Intel corporation.